

P1,P2: M-Y222E
 M-222D
 P3: M-426E

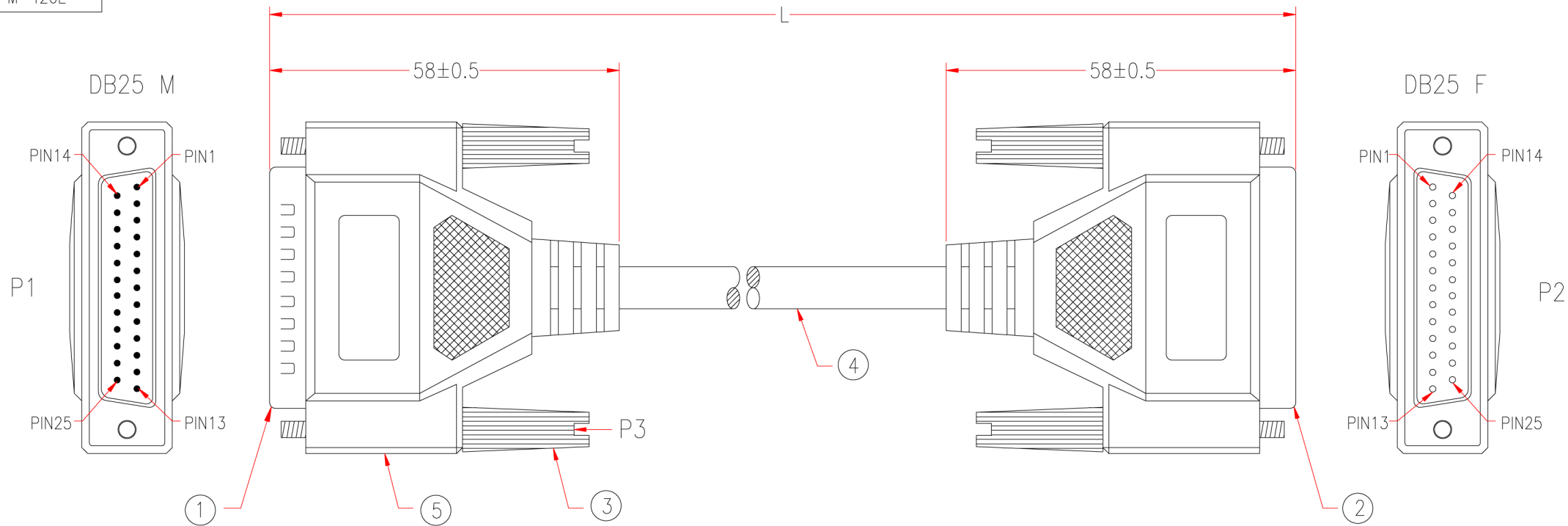

2006			
P1		P2	
1	—————	1	
2	—————	2	
3	—————	3	
Σ 1:1			
23	—————	23	
24	—————	24	
25	—————	25	
SHIELD	—————	SHIELD	

5	BLACK HEAT SHRINK TUBE ø3.0*30mm	2	M743
	ALUMINUM FOIL 33*110mm	2	M379
	MOLDED PE COLOR TRANSPARENT		TWN
	MOLDED PVC BEIGE		M304
4	NON-UL 25C 28AWG, ALUM-MYLAR FOIL SHIELDING WITH DRAIN WIRE, OD 7.0mm, JACKET BEIGE, DRAWING No. EMAL2825C-095	L-10mm	M304
3	MOLDED THUMBSCREW #4-40, LENGTH 46.5mm, BEIGE	4	M95
2	DB25 FEMALE, GOLD FLASH ON CONTACTS, BLUE INSULATOR	1	M83
1	DB25 MALE, GOLD FLASH ON CONTACTS, BLUE INSULATOR	1	M108
No.	DESCRIPTION	Q'TY	Supplier

APPROVED		25/25MF-X	Cable Length Unless Other Spec. Tolerances: 0 ~200mm ±10mm 201~1000mm ±20mm 1001 ~1500mm ±25mm 1501~2100mm ±30mm 2100mm↑ ±40mm
CHECKED	TIAN		
DRAWING	XIE		

DATE	03/MAR/06	ITEM NO.	2006	UNIT:mm	
------	-----------	----------	------	---------	--

CHECKED