

P1,P2: M-Y222D
M-222D
P3: M-426E

Customer No.: No.1

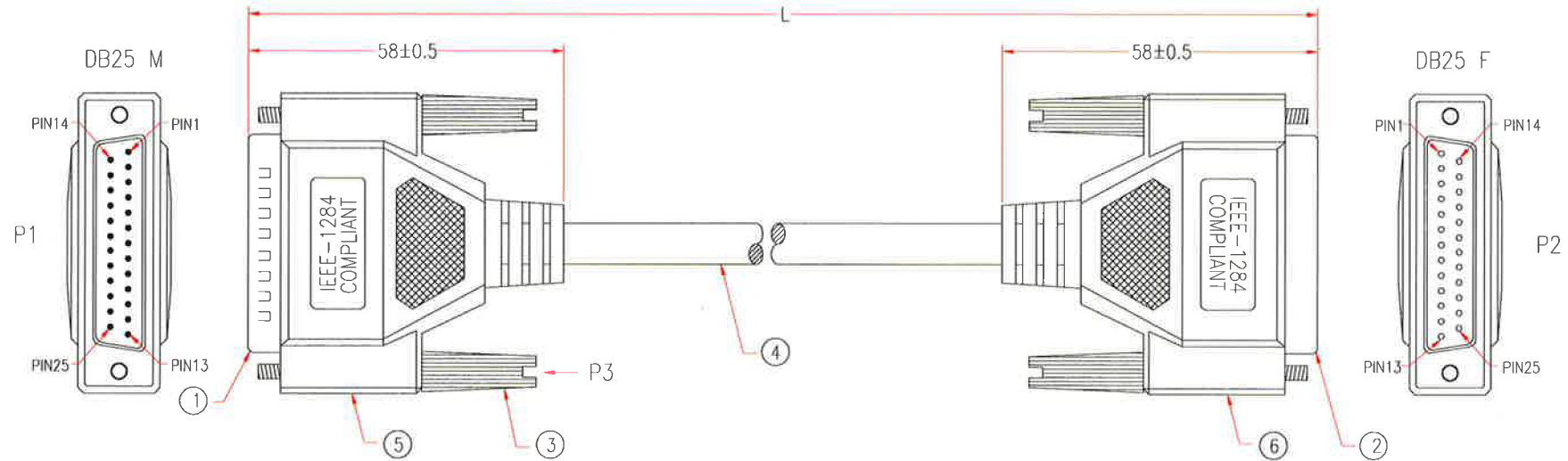

3102-2

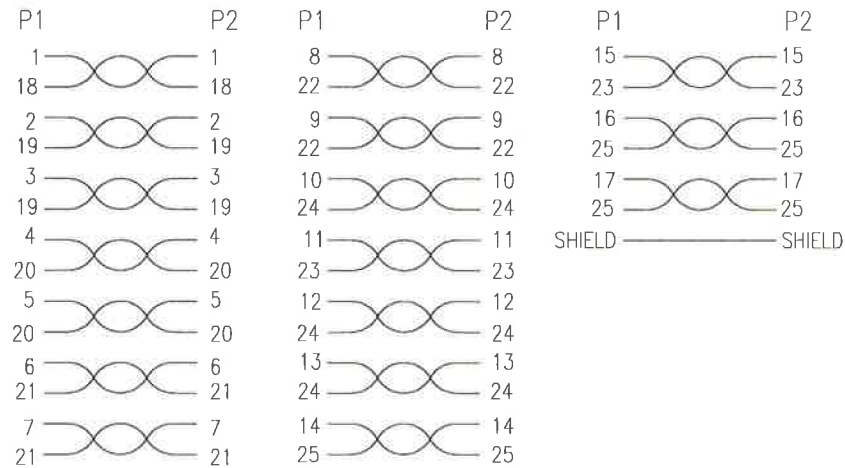

NOTE: All relevant materials are complied with RoHS directive.
Logo on double sides of overmold

5&6	BLACK PVC TUBE ϕ 3.0*30mm	2	M304
	COPPER FOIL 33*110mm	2	M309
	MOLDED PE COLOR TRANSPARENT		TWN
	MOLDED PVC BEIGE		M304
4	UL20276 18 TWISTED PAIRS 28AWG, ALUM-MYLAR FOIL AND AMA BRAID(64%) SHIELDING WITH DRAIN WIRE, OD 7.5mm, JACKET BEIGE, DRAWING No.EAAB2818P-231	L-20mm	M304
3	MOLDED THUMBSCREW #4-40, LENGTH 46.5mm, BEIGE	4	M95
2	DB25 FEMALE, GOLD FLASH ON CONTACTS, BLUE INSULATOR	1	M108
1	DB25 MALE, GOLD FLASH ON CONTACTS, BLUE INSULATOR	1	M108
No.	DESCRIPTION	Q'TY	Supplier
APPROVED		Cable Length Unless Other Spec. Tolerances:	
CHECKED	TIAN	0 ~200mm	±10mm
		201~1000mm	±20mm
		1001~1500mm	±25mm
		1501~2100mm	±30mm
		2100mm↑	±40mm
DATE	24/JUN/08	ITEM NO.	10E2-052XX
		UNIT:mm	

2008.6.24

MODIFY CABLE

CHECKED