

P1,P2: M-Y219A
 M-219B
 P3: M-426E

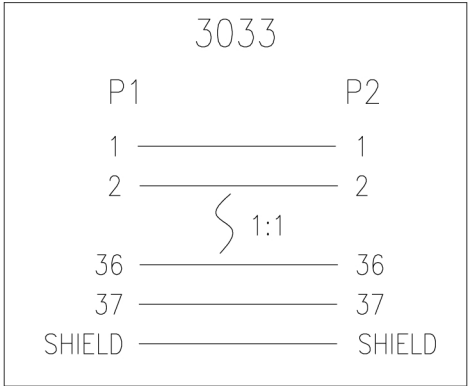
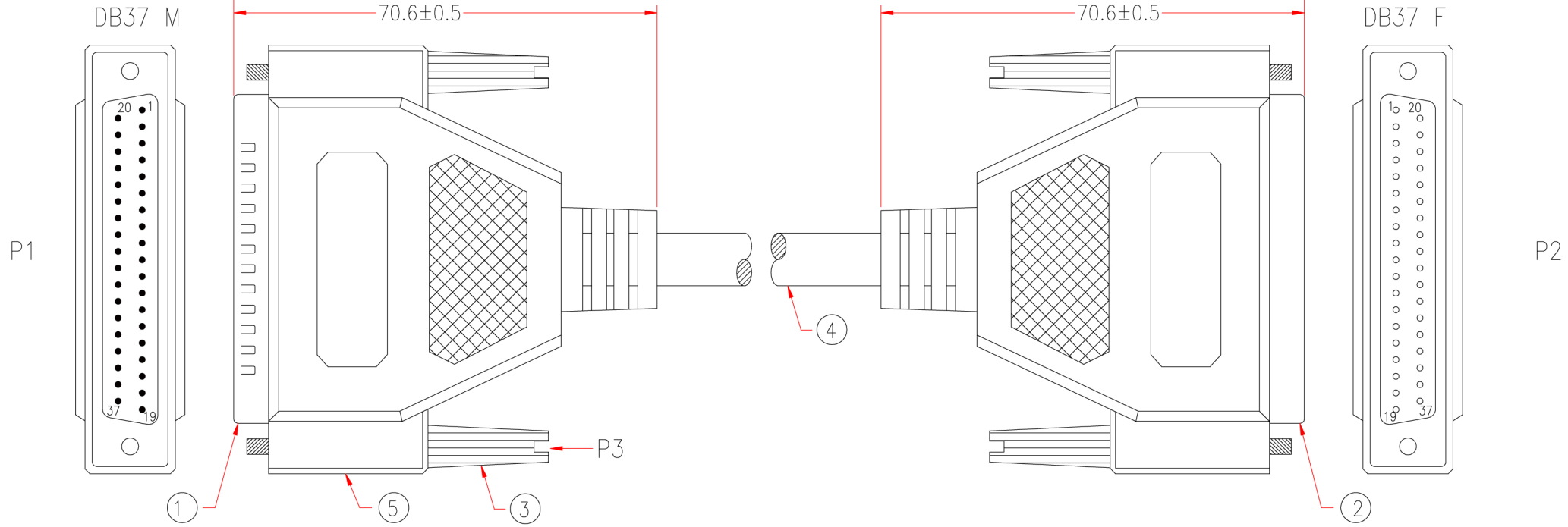

5	BLACK PVC TUPE $\phi 3.0 \times 42\text{mm}$	2	M304
	ALUMINUM FOIL 33*110mm	2	M309
	MOLDED PE COLOR TRANSPARENT		TWN
	MOLDED PVC BEIGE		M304
4	NON-UL 37C 28AWG, ALUM-MYLAR FOIL SHIELDING WITH DRAIN WIRE, OD 8.5mm, JACKET BEIGE	L	M304
3	MOLDED SCREW #4-40, LENGTH 46.5mm, BEIGE	4	M95
2	DB37 FEMALE, GOLD FLASH ON CONTACTS, BLUE INSULATOR	1	M108
1	DB37 MALE, GOLD FLASH ON CONTACTS, BLUE INSULATOR	1	M108
No.	DESCRIPTION	Q'TY	Supplier

APPROVED				Cable Length Unless Other Spec. Tolerances: 0 ~0.2M $\pm 0.01\text{M}$ 0.21~1.0M $\pm 0.02\text{M}$ 1.1 ~1.5M $\pm 0.025\text{M}$ 1.51~2.1M $\pm 0.03\text{M}$ 2.1M \uparrow $\pm 0.04\text{M}$
CHECKED	Ran			
DRAWING	TIAN	ITEM NO.	3033	