

REV.	DATE	FILE No.
1.0	2012-3-29	CC506B-0.5M

500±5mm
1000±10mm
2000±20mm
3000±20mm

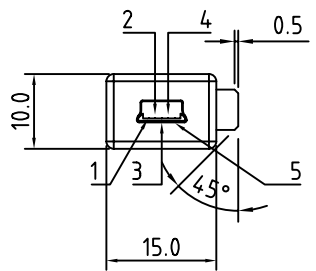
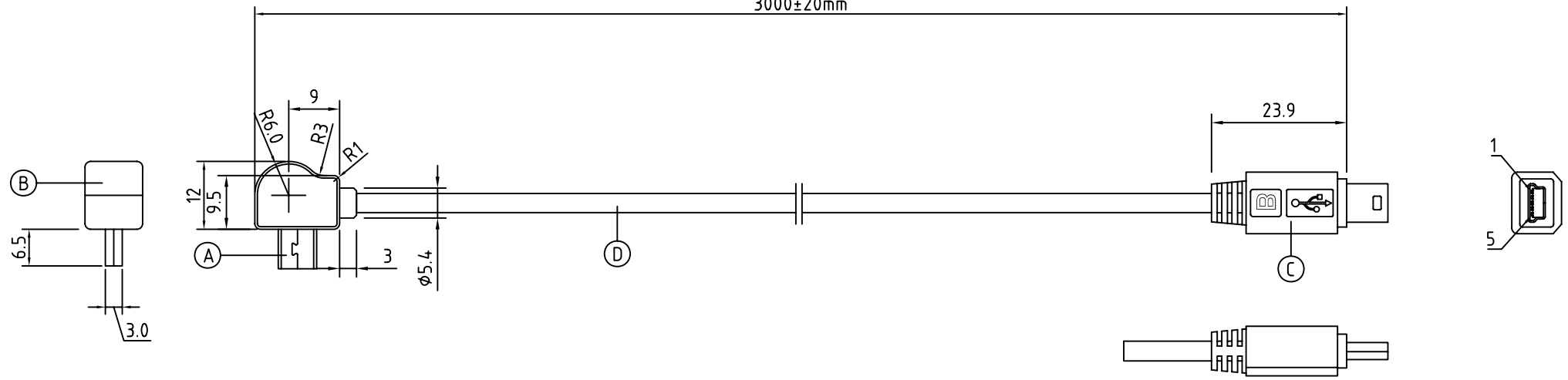

WIRING DIAGRAM

USB (B)(90c) 5PIN MALE	USB (B) 5PIN MALE	
1	1 RED	28AWG
2	2 GREEN	30AWG
3	3 WHITE	30AWG
5	5 BLACK	28AWG
SHELL	SHELL	

SPECIFICATION:

ITEM	PART NAME	MATERIAL	COLOR	QTY.
A	USB-M-N-5P-13.5 MINI 5PIN MALE	P.B.	NICKEL	2SET.
B	MODEL TY-XXX TYPE (NEW)	PVC	BLACK	1
C	MODEL TY-559 TYPE	PVC	BLACK	1
D	UL2725-MINI BK (1P×30#+2C×28#+AL+D+B#3.4MM	PVC	BLACK	0.5M

NOTE:ALL MATERIAL ARE COMPLIANT TO "RoHS".

CUSTOMER: DIGGELMANN		Tai Yip Electrical Co., Ltd.
CUST. P/N: CC506B-0.5M/BK		
S/O:	S/N:	PART No.: CC506B-0.5M/BK
DRAWING No.	CC-506-01	PART NAME: USB MINI (B) 5P.(90c)MALE TO USB MINI(B)5P MALE
DRAWN BY	Lingqi Meng	UNLESS OTHERWISE SPECIFIED, ALL DIMENSIONS ARE IN MM. TOLERANCE:DECIMAL .X ±0.1 .XX ±0.05 ANGLE ±1/2°
CHECKED BY	Zhongjiao	
APPROVED BY	Chenhan	
		SHEET 1 OF 1
		SCALE NO