

REV.	DATE	FILE No.
1.0	2007-12-29	CC474-MF-2M GY

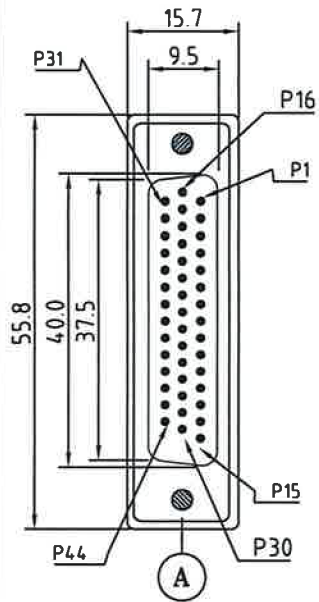

44PIN MALE

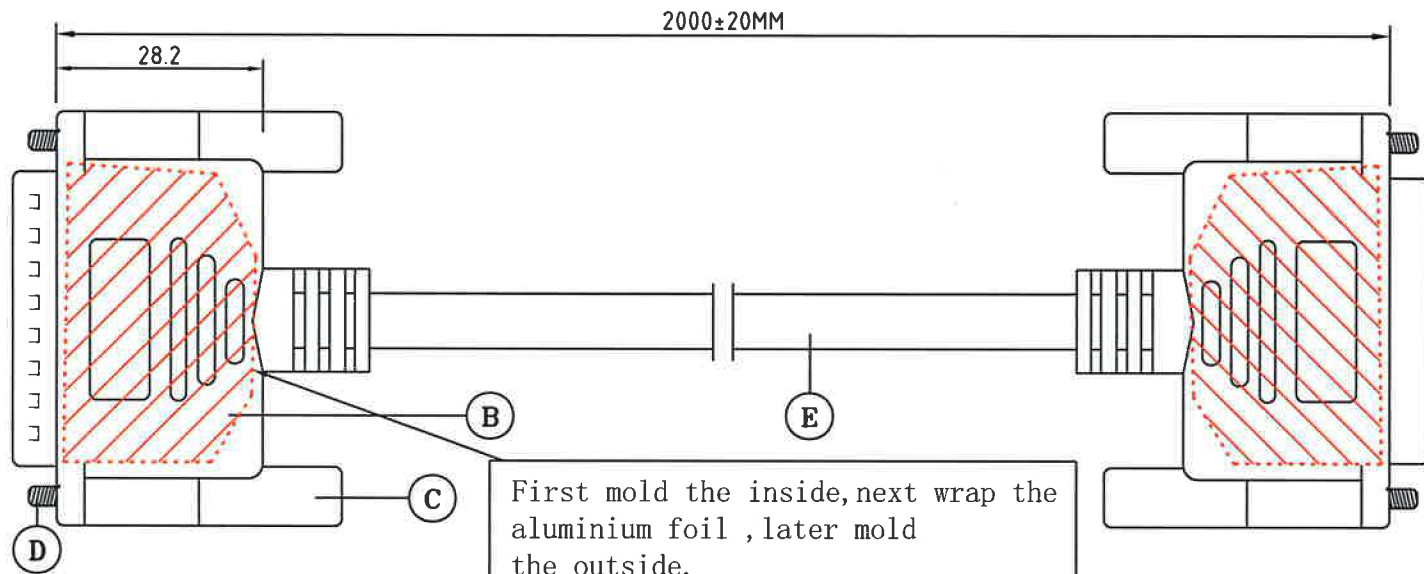

First mold the inside, next wrap the aluminium foil, later mold the outside.

先啤内模, 再包铝箔纸, 最后成型外模.

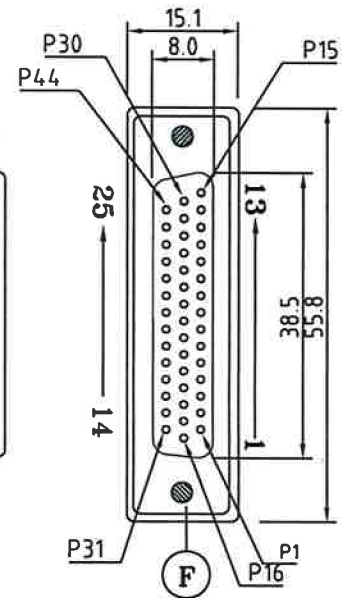

44PIN FEMALE

WIRING DIAGRAM
HD44P.MALE HD44P. FEMALE

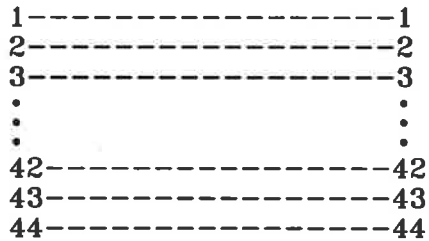

SHELL-----SHELL

对应接线

SPECIFICATION:

ITEM	PART NAME	MATERIAL	COLOR	QTY.
A	GHD44-FSN101-OK HDDF	P.B.	NICKEL	1SET
B	MODEL TY-275 TYPE	P.V.C	GREY	2
C	MODEL TY-276 TYPE	P.V.C	GREY	4
D	TS040X400TNOPO SCREW PLATRD	MILD ST.	NICKEL	4
E	(0.12/7TX44C+0.16/7T+AL)X1C O.D.9.5MM	P.V.C	GREY	2M
F	GHD44-MSN101-NK HDD44M	P.B.	NICKEL	1SET

CUSTOMER: DIGGELMANN		PART No.:
CUST P/N: HD44/44MF-2		
S/O: 12375/07	S/N:	PART NAME: RS 232 CABLE HD44M-HD44F(MOLDED)
DRAWING No.		UNLESS OTHERWISE SPECIFIED ALL DIMENSIONS ARE IN MM
DRAWING BY	LingQi.M	TOLERANCE:DECIMAL .X ±0.1
CHECKED BY	WenZhan.Z	.XX ±0.05
APPROVER BY	WenZhan.Z	ANGLE ±1/2°

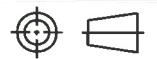

SHEET 1 OF 1
SCALE NO