

REV.	DATE	FILE No.
1.0	2006-06-14	CC317-FM-1.8M

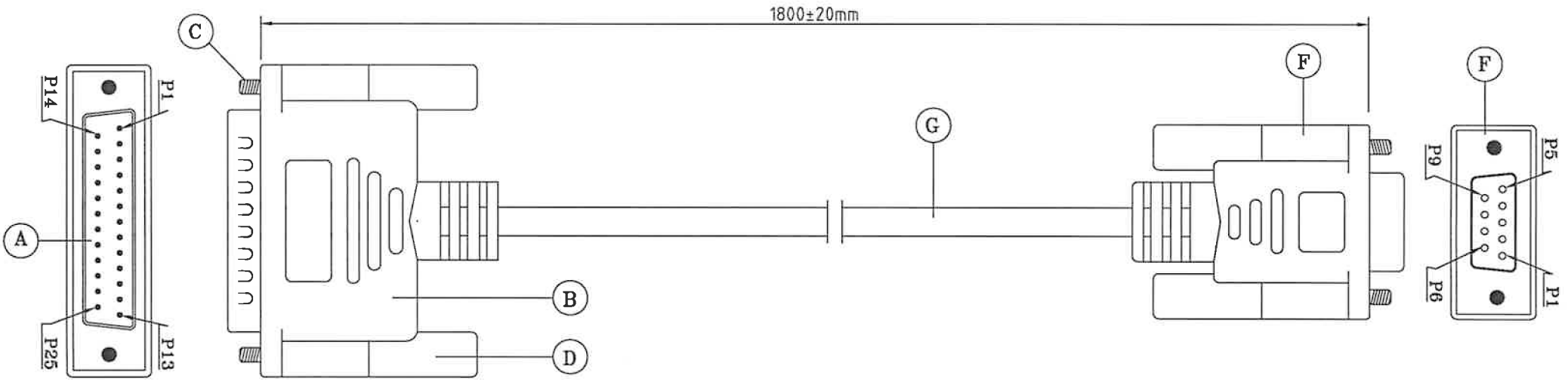

25P. MALE

9P. FEMALE

SPECIFICATION:

ITEM	PART NAME	MATERIAL	COLOR	QTY.
A	25P.D-SUB SOLDER TYPE "M" BLUE	P.B.	NICKEL	1SET.
B	MODEL TY-275 TYPE	P.V.C	BE	1
C	TS040X376TNOPO SCREW PLATED	MILD STEEL	NICKEL	4
D	MODEL TY-129 TYPE	P.V.C	BE	4
E	9P.D-SUB SOLDER TYPE "F" BLUE	P.B.	NICKEL	1
F	MODEL TY-276 TYPE	P.V.C	BE	1
G	(0.12/7TX5C+0.16/7T+AL)X1C O.D.5MM 9T+1T/BE-02B	P.V.C	BE	1.8M

WIRING DIAGRAM

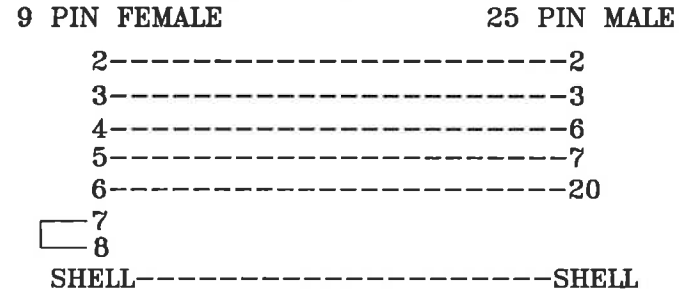

CUSTOMER: DIGGELMANN			Tai Yip Electrical Co.,Ltd	
CUST P/N:DB9F/DB25M(KAB-135)				
S/O: #05974/06	S/N:	PART No.: CC317-FM-1.8M/BE-R		
DRAWING No.		PART NAME:RS 232(9C+1)DB9F-DB25M(MOULD)		
DRAWING BY	LingQi.M	UNLESS OTHERWISE SPECIFIED ALL DIMENSIONS ARE IN MM TOLERANCE:DECIMAL .X ±0.1 .XX ±0.05 ANGLE ±1/2°		
CHECKED BY	WenZhan.Z			
APPROVER BY	WenZhan.Z			
		SHEET 1 OF 1		SCALE NO