

REV.	DATE	FILE No.
1.0	2007-2-13	CC319-MM-2M-5R

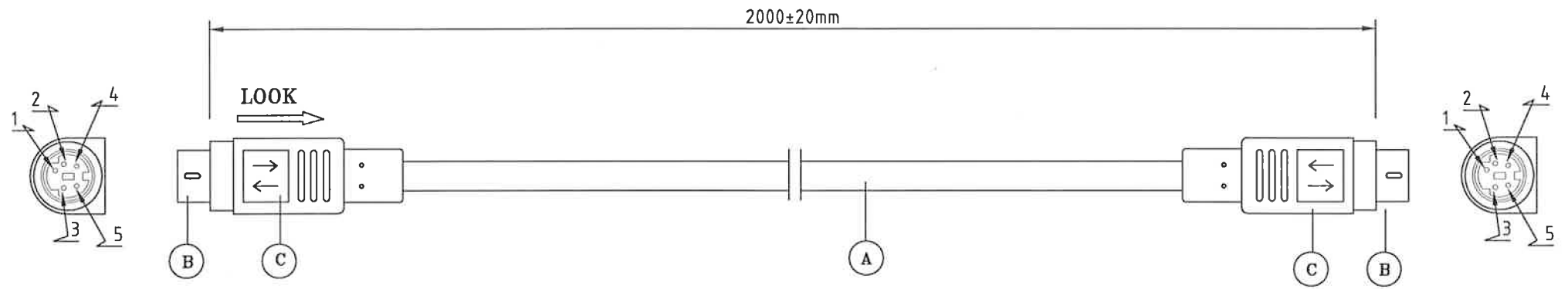

WIRING DIAGRAM

5P.MINI DIN MALE	5P.MINI DIN MALE
1-----1	1-----1
2-----2	2-----2
3-----3	3-----3
4-----4	4-----4
5-----5	5-----5
SHELL-----SHELL	SHELL-----SHELL

SPECIFICATION:

ITEM	PART NAME	MATERIAL	COLOR	QTY.
A	(0.12/7TX5C+0.16/7T+AL)X1C #5MM	P.V.C.	GREY	2M
B	Y/D285 5PIN MINI DIN MALE METAL	P.B.	NICKEL	2
C	MODEL TY228 TYPE	P.V.C	GREY	2

NOTE:ALL MATERIALS ARE RoHS.

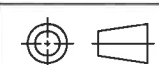
CUSTOMER: DIGGELMANN		PART No.: MD5/5MM-2
CUST P/N: MD5/5MM-2		
S/O:	S/N:	
DRAWING No.	CC-319-07	PART NAME: 5P.MD MALE TO 5P.MD MALE(RoHS)
DRAWING BY	LingQi.M	UNLESS OTHERWISE SPECIFIED ALL DIMENSIONS ARE IN MM TOLERANCE:DECIMAL .X ±0.1 .XX ±0.05 ANGLE ±1/2°
CHECKED BY	WenZhan.Z	
APPROVER BY	WenZhan.Z	
		
		SHEET 1 OF 1
		SCALE NO