

REV.	DATE	FILE No.
1.0	2005-10-8	

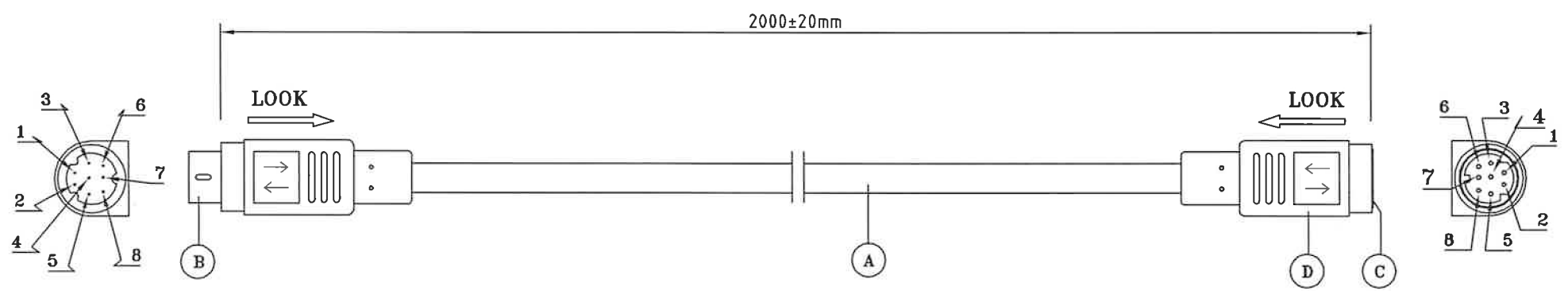

WIRING DIAGRAM

8P.MINI DIN MALE 8P.MINI DIN FEMALE

- 1-----1
- 2-----2
- 3-----3
- 4-----4
- 5-----5
- 6-----6
- 7-----7
- 8-----8
- SHELL-----SHELL

SPECIFICATION:

NO.	PART NAME	MATERIAL	COLOR	QTY.
A	(0.12/7TX8C+0.16/7T+AL)X1C #5MM	P.V.C.	GREY	2M
B	D288 8PIN MINI DIN MALE METAL	P.B.	NICKEL	1
C	D288 8PIN MINI DIN FEMALE METAL	P.B.	NICKEL	1
D	MODEL TY22B TYPE	P.V.C	GREY	2

NOTE:ALL MATERIALS ARE RoHS. GREY:S72

CUSTOMER: DIGGELMANN		MD8/8MF-2
CUST P/N: 8/8MF-2/		
S/o: 9029/05	S/N:	PART No.:
DRAWING No.		PART NAME: 8P.MINI DIN MALE TO 8P.MINI DIN FRMALE
DRAWING BY	LingQi.M	UNLESS OTHERWISE SPECIFIED ALL DIMENSIONS ARE IN MM TOLERANCE:DECIMAL .X ±0.1 .XX ±0.05 ANGLE ±1/2°
CHECKED BY	WenZhan.Z	
APPROVER BY	WenZhan.Z	
		SHEET 1 OF 1
		SCALE No